



ZDT-300 DC Earth Fault Locator
1 M Ω Version
User Manual

Kehui International Ltd
2 Centrus, Mead Lane, Hertford
Hertfordshire, UK, SG13 7GX
Phone: (44) 1920 358990
Website: <http://kehui.com>

Legal Notices

The copyright of this material belongs to Kehui International Ltd. No company or individual may extract, copy or translate in any way without the written permission of the copyright owner. Copyright infringement will be investigated.

This product complies with the design requirements for environmental protection and personal safety.

This product is a professional instrument specially designed for power cable faults. Please do not use it for any other purpose. The company assumes no responsibility or loss if it is used for other purposes.

The safety regulations in this user manual should be strictly adhered to.

The storage, use and disposal of the product should be in accordance with the product manual, relevant contracts or relevant laws and regulations.

As part of Kehui's continual product development this product is subject to design or technical changes without prior notice. When product improvement or technical changes occur, you can check the information through Kehui International Ltd. website <http://www.kehui.com>.

Disclaimer: Every effort has been made to make this material complete, accurate, and up-to-date. In addition, changes are periodically added to the information herein; these changes will be incorporated into new editions of the publication. Kehui International Ltd reserves the right to make improvements and/or changes to the product(s) and/or the program(s) described in this document without notice, and shall not be responsible for any damages, including but not limited to consequential damages, caused by reliance on the material presented, including but not limited to typographical errors.

NOTE: Windows is a registered trademark of Microsoft.

Revision history:

Data version	Revision date	Revision reason	Person
V1.0	2020.08.13	New Issue	BilKib
V1.1	2020.09.23	Revision	BilKib
V2.0	2020.11.20	New features and diagrams	DiaKib, BilKib
V2.1	2021.02.01	Revised diagram	DiaKib, BilKib
V2.2	2022.03.11	IMQ version created	EiZhong, BilKib

Document number: ZDT-300_V2.2_UM_EN





Table of Contents

SAFETY INSTRUCTIONS	4
1 GENERAL	5
1.1 General Information	5
1.2 Working Principle	6
1.3 Features	7
1.4 Specifications	8
2 LAYOUT	9
2.1 Transmitter	9
2.2 Receiver	10
2.3 Clamp	11
2.4 Current sensor.....	11
3 SET-UP	12
3.1 Transmitter	12
3.2 Receiver	15
4 FAULT FINDING	18
4.1 Pre-location	18
4.2 Fault location modes	18
4.3 Current Differential mode	18
4.4 Current Waveform Mode	20
4.5 Tree method for fault pinpointing	21
4.6 Typical fault pinpointing process	21
5 TRANSPORTATION, STORAGE AND CHARGING	23
5.1 Transportation considerations	23
5.2 Storage conditions, storage period and precautions	23
5.3 Instrument power and charging.....	23
5.4 Battery replacement	23
5.5 Unpacking and Inspection	23
6 MAINTENANCE	24
7 WARRANTY	24
8 APPENDIX A: ZDT-300 PACKING LIST	25

Safety Instructions

Safety Note: This user manual is the basic commissioning and on-site operation guide for the ZDT-300 DC Earth Fault Locator. All operators of the ZDT-300 should read the contents of this manual in advance. The manufacturer of this product is not responsible for any loss caused by the operator's failure to comply with the operating procedures of this manual or for violation of the safe working procedures of the operator.

Meaning of the manual symbols Important instructions concerning personal safety, operating procedures, technical safety, etc., are marked with the following symbols:

Symbol	Meaning
	Indicates a potential hazard that could result in serious or fatal injury
	Indicates a potential hazard which, if not avoided, may result in minor personal injury or property damage.
	Indicates that it contains important information and useful guidance for using this product. Failure to heed this information may result in the test not functioning properly.
	Indicates that this is a useful guideline based on field practice.

Use of accessories: Please be sure to use Kehui's spare parts to ensure the safe and reliable use of this instrument. Using accessories made by other companies will make any warranty null and void.

Repair and maintenance: This instrument must be repaired and maintained by Kehui or an agent authorised by Kehui. If you have any questions concerning the product and its application, please contact the company at info@kehui.com.

Terminology Throughout the document, the word Earth has been used, this term is considered synonymous with Ground and is used as the electrical reference point.

1 General

1.1 General Information

The DC system in a substation provides power to a variety of equipment involved in the control and protection of the electrical power system. It is therefore very important that this system is working correctly. As the DC system is a floating unearthed system, an earth fault on one terminal will not cause any disturbance and the system will continue to run normally. However, should an earth fault occur simultaneously on the other terminal, it will result in a virtual short-circuit between the two terminals through the earth, causing the failure of the DC supply in the substation. To prevent this, it is important to identify the fault location quickly and precisely when the initial fault occurs.

The ZDT-300 DC Earth Fault Locator has been developed for the fast location of earth faults on the DC system to ensure the damage which would occur in the event of a second fault is avoided. The system quickly and accurately finds the fault point, while overcoming the influence of the distributed capacitance of the system, greatly improving the accuracy of the measurement. It provides effective location of high resistance faults, low resistance faults, faults creating system loops, on systems with single or multiple faults. It can also identify the presence of AC interference on the DC system.



Figure 1.1: ZDT-300 Equipment

1.2 Working Principle

The working principle of the ZDT-300 is shown in Figure 1.2 below:

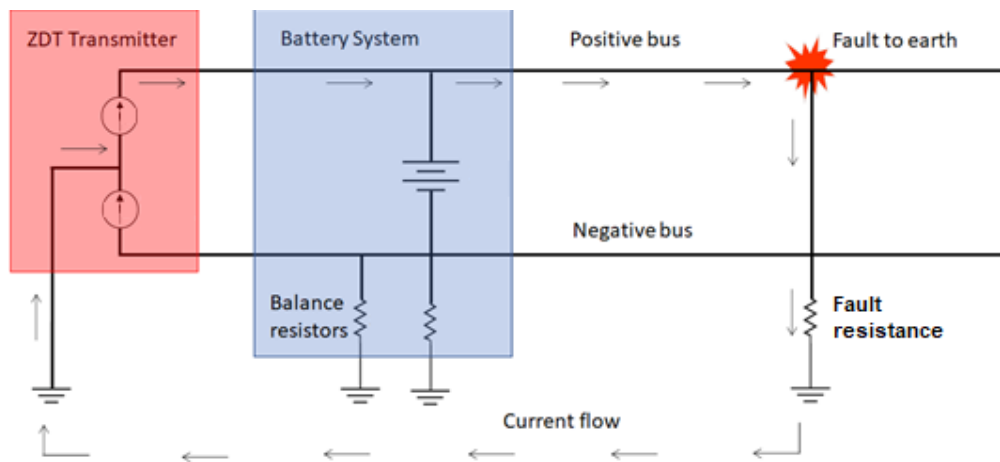

Figure 1.2 Working principle of the ZDT-300

The Transmitter unit of the ZDT-300 can measure the voltage of both the positive and negative buses. If one of them is faulty, the measured voltage will be depressed, allowing the faulted bus to be identified. It will then inject a small current signal into both the positive and negative buses and from this, it can calculate the balance resistance, fault resistance and system capacitance.

The locator uses an isolated programmable constant current source to inject a series of small current pulses into the system. Each pulse will flow along the faulty bus, and finally go to earth at the resistive fault point, which appears to it as an earthing resistance. The receiver will be applied to the system at different points to determine where the fault current is flowing. It calculates and displays the magnitude and direction of the resistive current in real time, allowing the relative position of the fault to be identified. If the clamp is positioned in front of the fault position, it will detect the magnitude of the injected current signal; if it is clamped beyond the fault position, the injected current signal cannot be detected by the clamp; hence the ground fault point is between the two points. In this way, it can be used to pinpoint the fault along the faulty bus by identifying the point at which the signal is lost, this being the fault point.

The use of the injection of voltage pulses up to 1kV by the ZDT-300 will have no effect on equipment connected to the DC system because the pulses are injected across the fault and not across the system buses, as explained in point 1. Furthermore, equipment on the DC system will be tested to the relevant IEC standards which allow for voltage impulses of up to 1500V, well beyond the level used in the device. The output is a square wave with an automatically selected frequency of 1 Hz, 0.5 Hz or 0.2 Hz with the highest output voltage being applied at the lower frequencies, at 1 Hz it is limited to 300V.

Taking the common 220V DC system as an example. This is defined such that the voltage between the positive bus and the negative bus is 220V; this device detects the voltage from the positive bus to earth and the negative bus to earth respectively. This is called the fault bus; and is used to detect the magnitude of the earth fault resistance.

The current signal from the device results from the injection of a constant current with voltage-limiting. The current signal flows in the loop from the fault bus to earth and is not injected between the positive and negative buses. The injection of this low current signal will not affect the 220V voltage between the positive and negative buses, and will not damage the load equipment. The voltage between the positive and negative buses is always 220V.

Using a fault on a standard 220V DC system as an example; the equipment detects that the voltage of the positive busbar to earth is 55V, and the negative busbar to earth is 165V, hence, it is determined that there is a fault between the positive busbar and earth. Assuming the detected earth fault impedance is 50k Ω ; the injection voltage level selected by the equipment is DC 500V; the detection process starts, such that the current path of the injection loop is from the positive bus, through the fault impedance to earth and back to the device. The maximum value of this current is 5mA and, during this current injection process, the voltage between the positive bus and the negative bus is always DC 220V;

The following cases explain the injected current-limiting and voltage-limiting signals, assuming that the injection voltage level is 500V:

- i. If the current reaches 5mA before the voltage reaches 500V, then the voltage does not increase any further (this voltage refers to the voltage of the faulty bus to earth and not the voltage between the positive and negative bus, which is always DC 220V).
- ii. If the injected voltage reaches 500V and the current does not reach 5mA, then the current will remain at the value reached (<5mA), the voltage will not increase further.

1.3 Features

- ZDT-300 can directly locate earth faults on the DC system, with no need to cut any cables, thus increasing the power network reliability.
- Two modes of operation; Current Differential mode and Current Waveform mode.
- In current difference mode, the receiver can calculate the difference between the pre-injected and post-injected current values to determine the fault point in real time; the real-time calculation shows the resistive current, greatly improving the test sensitivity and allowing insulation faults to be measured up to 1M Ω .
- In current waveform mode, the receiver uses digital signal processing to analyse the waveform and determine the fault point in real time.
- The unit can identify the presence of any stray AC voltage on the DC network, preventing damage to connected devices.
- The DC system voltage is identified automatically, and the output voltage is adjusted accordingly, e.g. 230V, 110V, 48V and 24V.
- The status of the system earthing is automatically checked with an alarm if an earth is present, which is usually due to a fault condition.
- Indication of the current direction, to assist with fault location.
- The transmitter detects fault information such as positive and negative bus voltage, fault resistance, grounding capacitance, and balance resistance in real time.
- The transmitter can be powered directly from the DC system. Where the voltage is insufficient to do this an alternative AC supply is available.
- The optimal output frequency of the transmitter is automatically determined by measuring the DC earth resistance and the distributed capacitance to earth.

- The receiver has an automatic power-off function, which operates if there is no activity within 60 minutes or there is insufficient voltage from the battery.
- Using wireless communication technology real-time data can be transmitted quickly and conveniently.
- Additional current sensor for applications where the current clamp is unsuitable due to the number of cables or the diameter of a single cable.

1.4 Specifications

➤ General

- Suitable for 220V, 110V, 48V and 24V DC system
- Earth resistance range 0 – 1MΩ
- Capacitance value; branch 47μF, total 150μF
- Environmental: temperature: -10 - 40°C, humidity: 10-90%RH, Altitude: 4500m

➤ Transmitter

- Transmitter power supply: DC 110V, 220V (self-powered from DC network) or AC 220V (for 24V or 48V DC networks).
- Voltage output:
 - Option 1: 250V
 - Option 2: 110V/250V/500V
 - Option 3: 110V/250V/500V/1000V
- Transmitting signal : ≤5mA rms
- Maximum distributed capacitance value to earth: branch ≤22uF, total ≤150uF.
- The range of measurable earth resistance when the transmitter is online (and the balancing resistance is removed):
 - When the injection voltage level is 1kV, 0 – 1MΩ
 - When the injection voltage level is 500V, 0 – 500kΩ
 - When the injection voltage level is 250V, 0 – 250kΩ
 - When the injection voltage level is 110V, 0 – 100kΩ
- Short circuit signal current ≤20mA
- Power consumption <15W
- Dimensions: 280mm × 220mm × 90mm
- Weight 2.00kg

➤ Receiver

- Power supply; Built-in rechargeable lithium battery, 20 hours continuous working, 3-4 hours charging time. (Note: Charging for 10-15 minutes will give an additional 30 – 50 minutes working time)
- Power consumption <2W
- The unit will shut down after no operation for 60 minutes or low battery voltage.
- Weight 0.90kg
- Dimensions: 220mm × 125mm × 55mm

➤ Current sensor

- Dimensions: 180mm × 60mm × 35mm

➤ Clamp

- Dynamic range: double wire clamp (positive and negative busbar clamp together) 0 – 40A (load)
- Single clamp range: -5A to +5A
- Power supply: two AA (No. 5) alkaline batteries, 10-20 hours continuous working
- Weight: 0.21kg
- Dimensions: 180mm × 60mm × 35mm

2 Layout

The ZDT-300 set is comprised of a transmitter, receiver, current clamp, current sensor (alternative to clamp) and connecting leads.

2.1 Transmitter

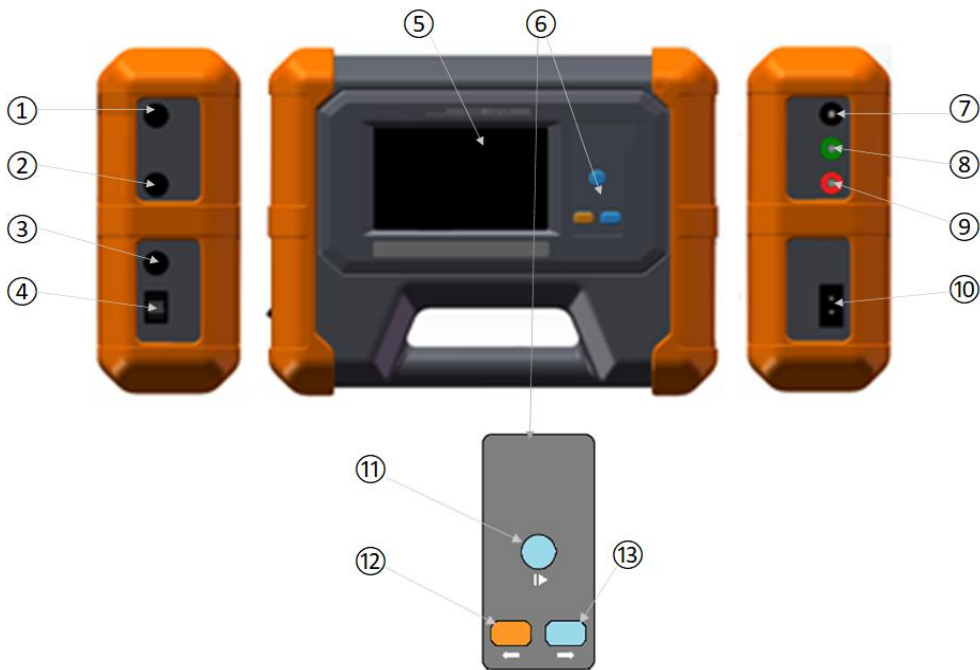

- | | |
|---|--|
| ① Positive output fuse | ⑧ Earth connection socket: connects to a suitable earthing point |
| ② Negative output fuse | ⑨ DC positive bus connection socket: connects to the positive pole of the DC system |
| ③ Power supply fuse | ⑩ AC 220V power jack: plugs in to the AC power supply, this is not required if the transmitter is powered from the DC system (>110V) |
| ④ On/Off switch | ⑪ Start/stop key |
| ⑤ LCD display | ⑫ Left key |
| ⑥ Keypad | ⑬ Right key |
| ⑦ DC negative bus connection socket: connects to the negative pole of the DC system | |

Figure 2.1 Transmitter

2.2 Receiver

The appearance of the Receiver is as in Figure 2.2 below:

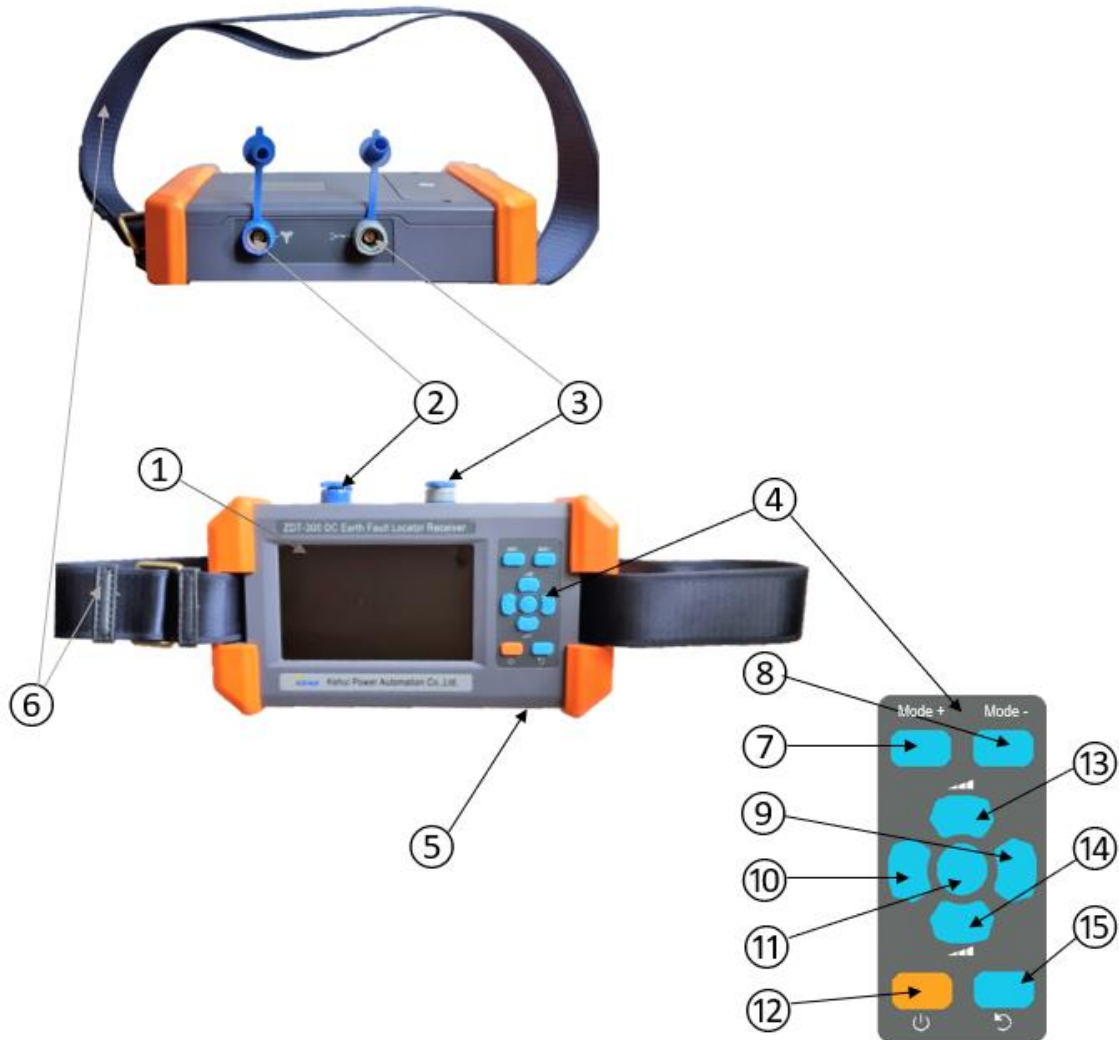

- | | |
|--|------------------------------|
| ① LCD display | ⑨ No function on this device |
| ② Signal socket: to connect the current sensor | ⑩ No function on this device |
| ③ Signal socket: to connect the clamp | ⑪ Start / Stop |
| ④ Integral keypad | ⑫ On / Off |
| ⑤ USB charging socket | ⑬ Gain + |
| ⑥ Neck strap | ⑭ Gain - |
| ⑦ Mode - | ⑮ Return |
| ⑧ Mode + | |

Figure 2.2 Receiver

2.3 Clamp

The appearance of the Clamp is as in Figure 2.3 below:

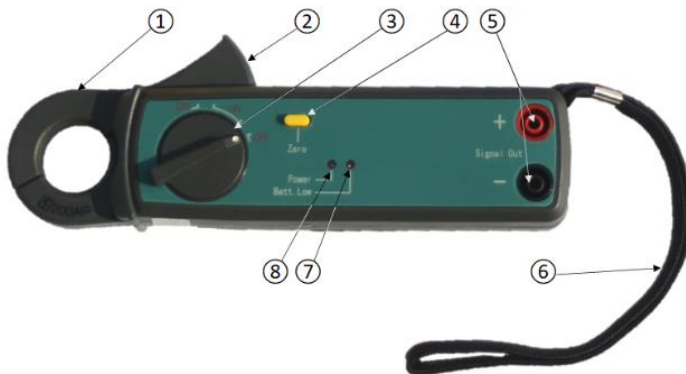

Figure 2.3 Clamp

- ① Clamp jaws.
- ② Handle: To open the clamp jaw.
- ③ On/Off switch: To power the clamp on or off.
- ④ Zero button: To zero the output voltage.
- ⑤ Signal output: Output sockets to connect to the receiver.
- ⑥ Wrist strap.
- ⑦ Low voltage indication: When lit, the voltage is too low, and a new battery is needed.
- ⑧ Power Indication: when illuminated, the clamp is switched on and working properly.



Always turn off the clamp after use as the batteries will run down.

2.4 Current sensor

When the diameter of the DC bus branch cable under test is greater than 25mm, the current clamp cannot be closed. Under these circumstances the current sensor can be used for testing. As the magnetic field induction loop of the current sensor is not closed, it is subject to external interference and so, it is recommended to not allow anybody to walk within 3 meters while the test is being carried out and to not move any large metal objects in the vicinity of the test to avoid interference.



The sensor does not require a power supply and is plugged in to the Receiver. The appearance of the sensor is as shown in the figure 2.4 below.

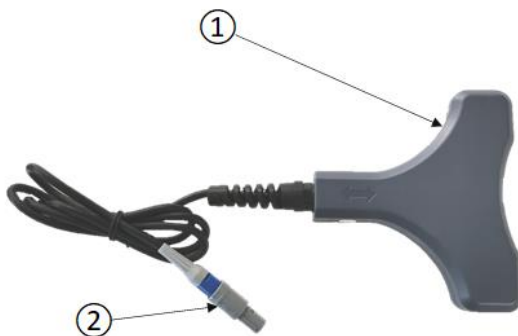

Figure 2.4 Current sensor

- ① Sensor, to be held adjacent to the cable under test
- ② Connection to Receiver

3 Set-up

If there is fixed earth fault detection device or alarm installed on the DC system, it should be switched off in order to use the ZDT-300 to detect a fault. The battery alarm relay should also be removed to increase the detection accuracy.

3.1 Transmitter



The transmitter is attached to the live DC network, only authorised personnel, trained in working on such systems should undertake this work. It must be ensured that all the correct live working precautions are taken before connecting the unit.

Connection



Ensure the transmitter is switched off. Firstly, connect the green crocodile clip to the earth of the DC system. It is important that this is securely attached to a proper system earth point or the ZDT may not work properly.

Where a DC system is equipped with a fixed earth fault detection device, it should be turned off, and any alarm relay should be unplugged to avoid interference with the test.

Connect the transmitter to the negative (-) and positive (+) buses. The black clip connects to the negative polarity (0v) and the red clip connects to the positive polarity as shown in figure 3.1. The busbars can normally be accessed inside the DC Distribution Board (DCDB).

When connecting the transmitter with the bus or faulty branches, always ensure that the red is connected to the positive bus, the black to the negative bus and the green to earth. Failure to comply with this will damage the instrument.

3.1.1 Power supply

If the DC system is 220V or 110V system, the ZDT-300 Transmitter is self-powered. If the system is 48V or 24V, the 220V AC power supply is used to power it.

3.1.2 Transmitter operation

The transmitter is connected as in Figure 3.1 with the requirement for AC supply determined by the magnitude of the DC voltage

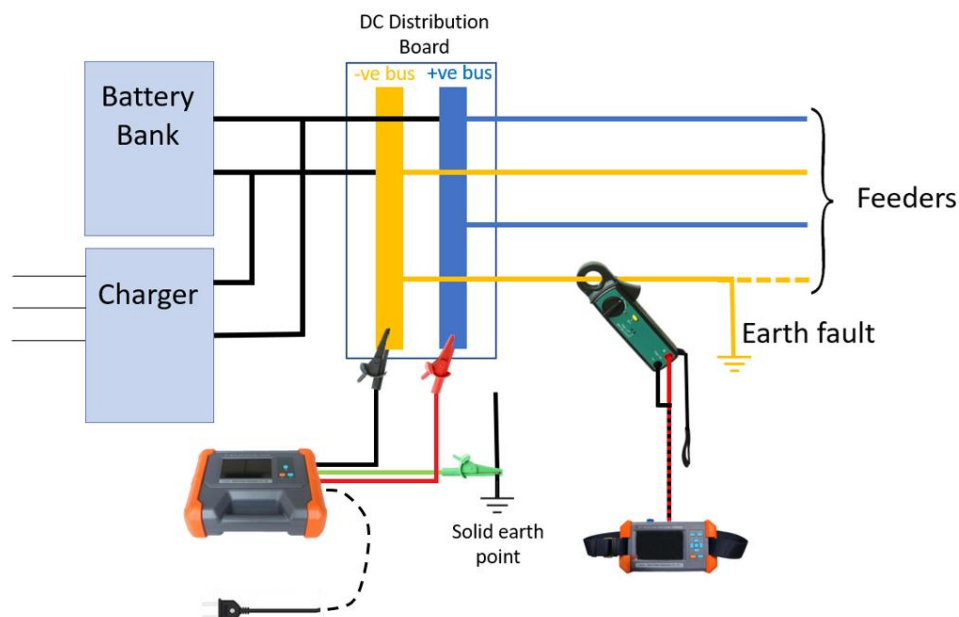

Figure 3.1 Transmitter connections



After the transmitter wiring is completed, turn on the transmitter power switch, the welcome interface is displayed after booting, and enter the voltage level selection interface after 1 second; as shown in Figure 3.2 (Note that only the voltage outputs included on the version of the ZDT-300 in use will appear). Care should be taken when using the transmitter due to the high voltages which may be present on its output.

The transmitter can measure the DC earth resistance and distributed capacitance to earth, and will automatically calculate the optimal output frequency.

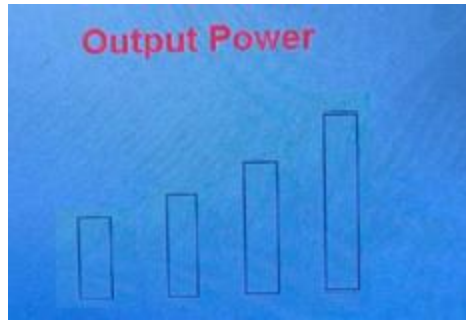

Figure 3.2 Voltage level selection interface



Figure 3.3 Voltage level selection confirmation

After confirming the voltage level selection (figure 3.3), the testing routine begins, the display is as shown in Figure 3.4. If during the testing process, there is a need to re-select the injection voltage level, it is necessary to restart the transmitter.

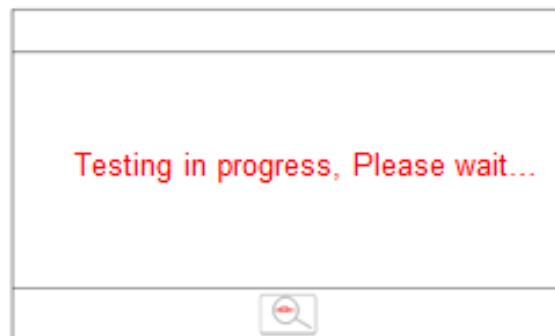

Figure 3.4 Testing display

After 2 seconds, if there is an error in the wiring, the resulting display is shown in Figure 3.5



Figure 3.5 Wiring error display

If there is any AC interference on the DC system, a warning appears as shown in Figure 3.6

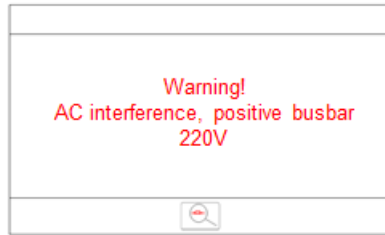

Figure 3.6 AC interference alarm display

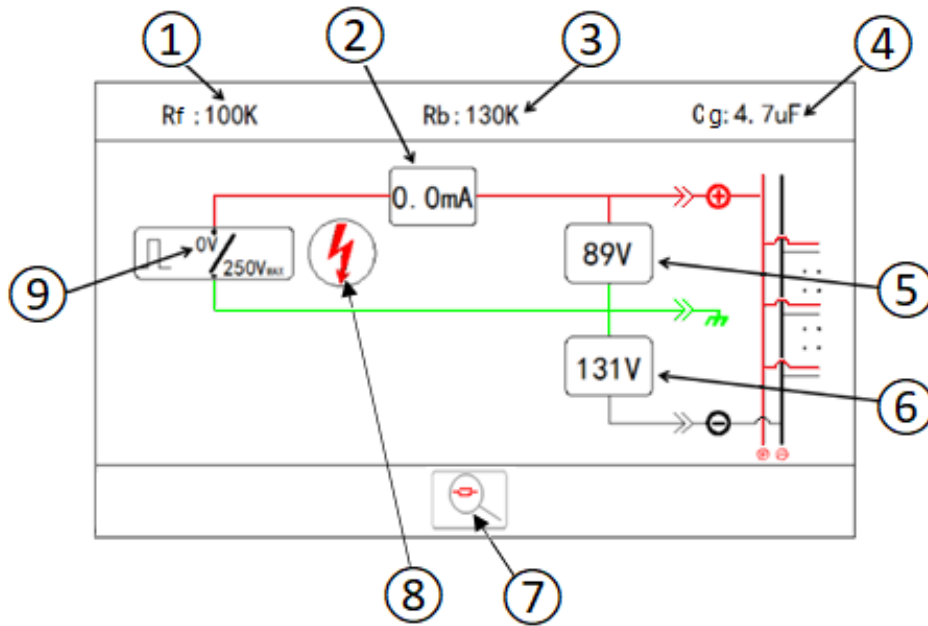

Figure 3.7 System parameter interface

- | | |
|---------------------------------------|-----------------------------|
| ① Fault resistance | ⑥ Voltage on healthy busbar |
| ② Current injected into faulty busbar | ⑦ Logo |
| ③ Balance resistance | ⑧ Fault present |
| ④ Capacitance to earth | ⑨ Injected voltage |
| ⑤ Voltage on faulty busbar | |

If the power-on test is to be performed without the equipment being connected to the DC system, from the testing screen, enter the demonstration interface and confirm whether a high voltage output is needed; if so, press the start/stop button of the receiver; if the high voltage injection is not required, press the start/stop button of the receiver again; the display interface is shown in Figure 3.8:

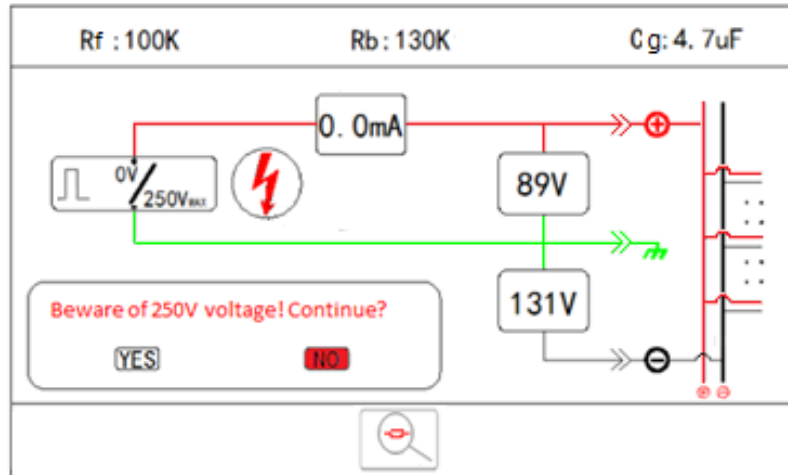

Figure 3.8 demonstration mode interface

3.2 Receiver

3.2.1 Connection

Connect the current clamp (or current sensor) signal cable to the receiver and turn on the clamp's power switch (Note: the current sensor does not need to be powered on). For clarity, the subsequent instructions will be based on using the clamp, however, they are equally applicable when using the current sensor. Press and hold the receiver's power button, the instrument will enter the welcome interface as shown in the figure. After 2 seconds, if the transmitter is not turned on, the receiver will enter the communication waiting interface until the transmitter turns on and enters the system parameter interface; the interface display is as shown in Figure 3.9 (Note the red cross to the right of the battery symbol, indicating there is no transmission between the two units):

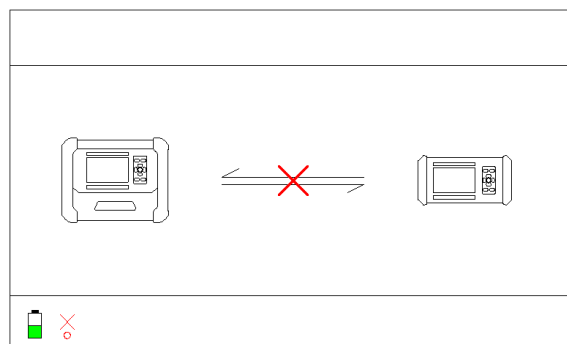

Figure 3.9 Communication waiting interface

After the transmitter is turned on and enters the system parameter interface, the receiver enters the main interface, which is shown in Section 3.2.2.

With the receiver displaying the main interface, fault location can commence based on the DC system information available. The Receiver will automatically power-off if there is no operation within 60 minutes, it will also turn-off if the battery is too low.

3.2.2 Display in current differential mode



Figure 3.10 Receiver main interface (current differential mode)

The features of the current differential mode interface are shown in figure 3.11:

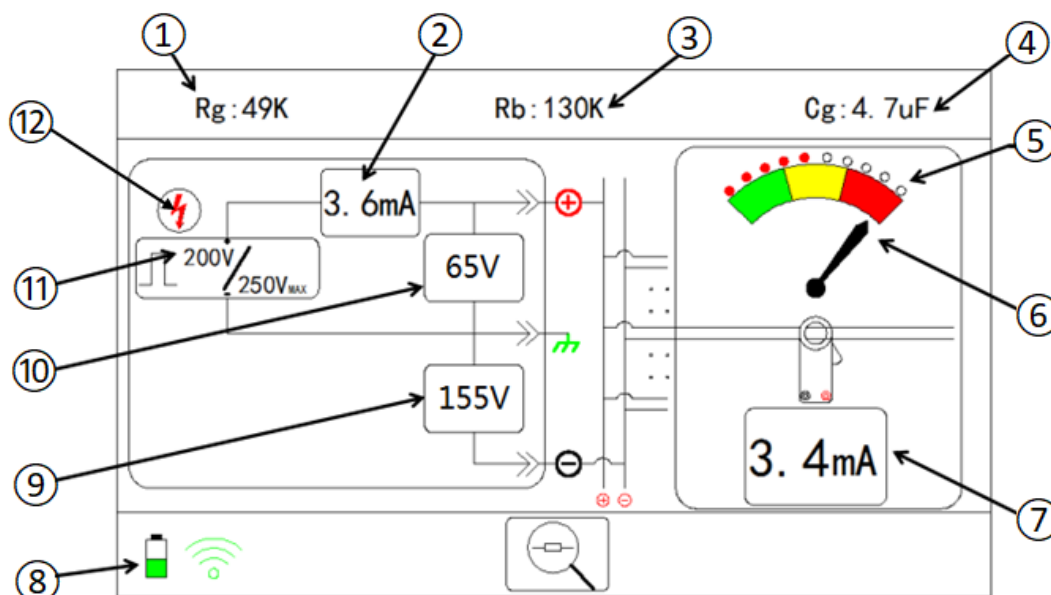

Figure 3.11: Details of receiver main interface for current differential mode

- | | |
|---------------------------------------|-------------------------------|
| ① Fault resistance | ⑦ Current measured by clamp |
| ② Current injected into faulty busbar | ⑧ Battery level |
| ③ Balance resistance | ⑨ Voltage on healthy busbar |
| ④ Capacitance to earth | ⑩ Voltage on faulty busbar |
| ⑤ Value of high voltage injected | ⑪ Injected voltage value |
| ⑥ Fault probability indicator | ⑫ Voltage injection indicator |



If the Receiver does not display a signal, check that the Clamp is switched on.

The Clamp uses high capacity alkaline batteries. If the battery indication is lit, it shows that the battery needs to be replaced. Ensure the polarity of the battery is correct, or it may damage the Clamp. Note that it does not power-off automatically, make sure that it is switched-off after using. If it is unused for a long time, the battery should be removed.



Due to the high sensitivity of the clamp, it should be held as steady as possible during the test. Otherwise, the geomagnetic field around the installation may affect the test results.

3.2.3 Display in current waveform mode

Selecting current waveform locating mode changes the screen to figure 3.12. The waveform will appear when the test is underway (see section 4.4)

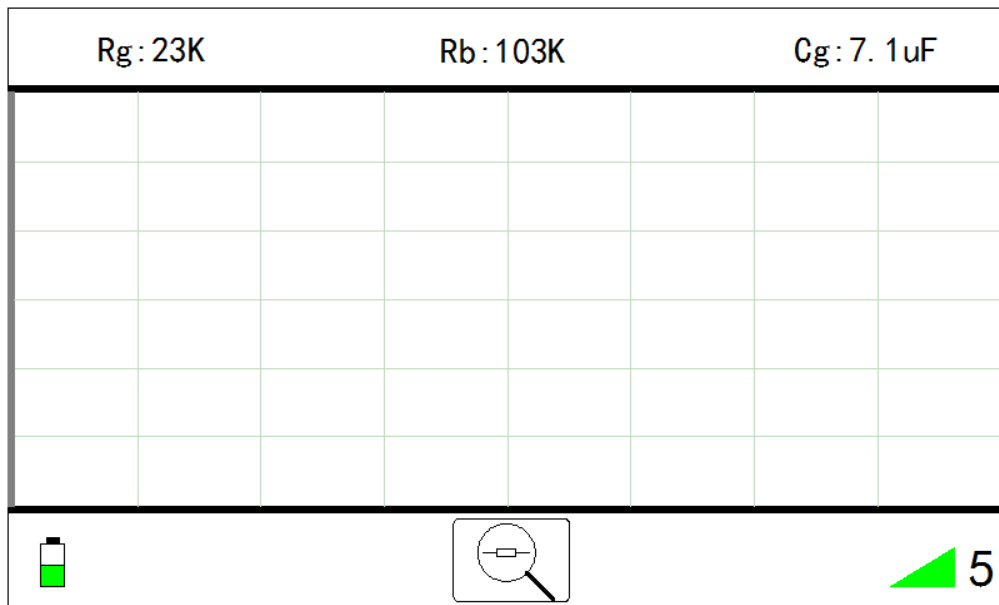

Figure 3.12: Current waveform locating mode



Due to the high sensitivity of the sensor, it should be held as steady as possible during the test. Otherwise, the geomagnetic field around the installation may affect the test results.

4 Fault Finding

4.1 Pre-location

Clip the clamp to the feeder under investigation (Figure 4.1), in this idealised case the transmitter has indicated that the fault is on the negative busbar.

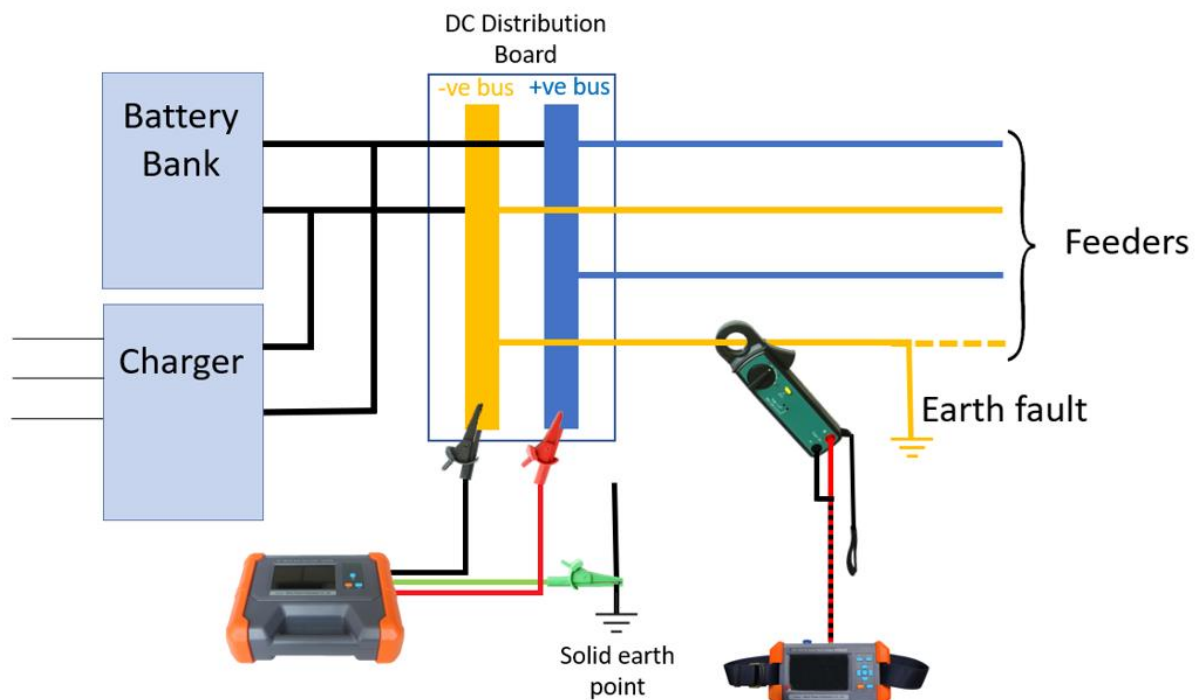

Figure 4.1 Fault finding

4.2 Fault location modes

The receiver can be used in either current differential or current waveform mode. When the current sensor is connected to the receiver, it will be automatically switched to current waveform locating mode. When the clamp is connected to the receiver, both modes are available.

4.3 Current Differential mode

Select the current differential mode using the mode selector buttons (figure 2.2 ⑦ and ⑧). After pressing the start-stop button (figure 2.2 ⑪), the receiver sends instructions to the transmitter. The transmitter will then start to output a high voltage at a frequency chosen automatically, depending on the DC fault impedance and the distributed capacitance to earth. The lightning icon (see ⑫ figure 3.10) on the receiver flashes to indicate the injection is in progress. The value of the faulty bus injection current is also updated in real time.

After making the initial location using the transmitter, the nature of the fault can be examined. Attention should be paid to the following conditions:

- If there is a large difference between the voltage of the positive bus and negative buses and the balance resistance is high ($>1\text{M}\Omega$), whilst the output signal of the transmitter is low, it may be an open circuit on the earth fault relay. Check the earth fault relay and ensure that it is disconnected.



- b) If there is not a large difference between the voltage of the positive and negative buses and the balance resistance is low ($<1k\Omega$), whilst the output signal of the transmitter is high, there may be faults on both buses. If fitted remove the earth fault relay and test it again. If the condition persists, it indicates that the negative and positive buses are both faulted.
- c) If there are any ambiguous results, where possible the test should be repeated. This time powering the Transmitter from an AC source.
- d) When there are two DC systems working in close proximity and the test results and signal output are abnormal (e.g. the positive has signal whilst the negative bus does not), it may be that the two DC systems have been confused. Check that the earth fault relay has been removed and test again.



During the test, the position of the current clamp (or sensor) can be determined relative to the fault point using the current detected, the faulty bus current and the number of high voltage injection pulses. Normally, when the number of high voltage injections exceed eight, the probability pointer can accurately determine whether the current position is faulty. Pressing the start-stop button will stop the high-voltage output from the transmitter.

If the current detected by the clamp is near 0.0mA, the fault indication probability pointer is in the green sector area, and it can be judged that there is no fault at the current position.

If the current detected by the clamp is close to the current of the faulty bus and the probability pointer of the fault indication is in the red sector, it is likely that there is a fault at the current position.



The current clamp gives a directionalised reading; if the fault bus current value is 4.0mA, but the value of current clamp detection current is about -4.0mA, it indicates that the clamp direction is reversed. If this is the case, remove the clamp, reverse it and re-apply it.

Every time the clamp is moved to a new detection point, it is recommended to press the clamp reset button for 1 second to ensure the accuracy of the detection current.

The clamp is very sensitive and so it is important not to move or shake it, otherwise the earth's magnetic field may influence the testing result.

Finding the earth fault requires a measurement of the resistive current flowing through the fault point using the current clamp. The branch with the earth fault has a resistive current which is not present in the healthy branches, which will exhibit a large capacitance to earth and therefore will have only capacitive current but no resistive current.

4.4 Current Waveform Mode

Select the current waveform mode using the mode selector buttons (figure 2.2 ⑦ and ⑧). After pressing the start-stop button (figure 2.2 ⑪), the receiver sends instructions to the transmitter. The transmitter will then start to output a high voltage at a frequency chosen automatically, depending on the DC fault impedance and the distributed capacitance to ground. The lightning icon (see ⑫ figure 3.10) on the receiver flashes, to indicate the injection is in progress; the value of the faulty bus injection current is also updated in real time.

The receiver will determine a fault point in real time based on the amplitude of the waveform. If there is a fault, the pulse waveform will appear as in figure 4.2.

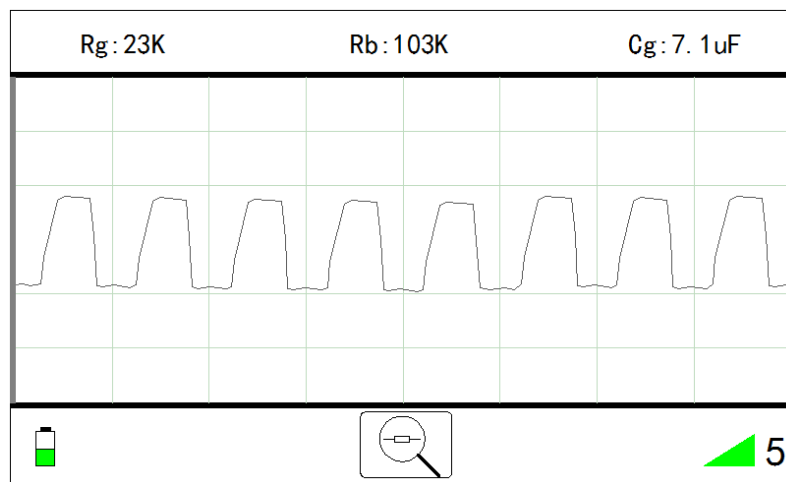

Figure 4.2 Current Waveform Mode fault display

if there is no fault, the display will be as in figure 4.3.

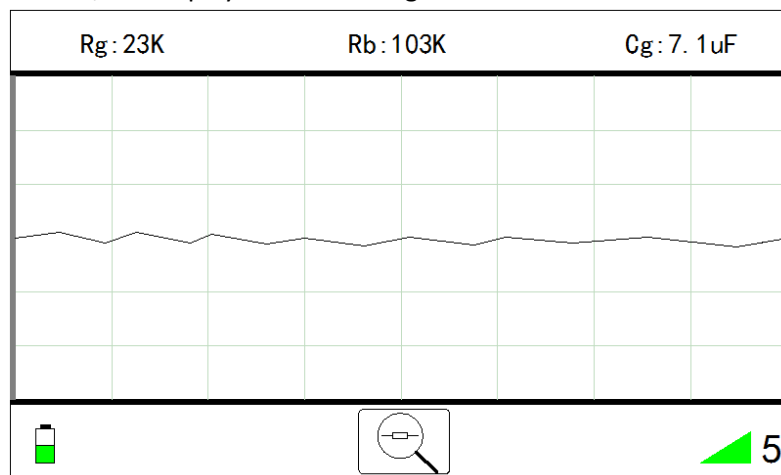

Figure 4.3 Current Waveform Mode display with no fault

Where no waveform is displayed the clamp should be moved to a new branch (see section 4.5).

Whenever the clamp is moved to a new branch, the reset button must be pressed (Figure 2.2 ⑮), to continue detecting until the faulted branch is detected. When the detection process is finished, press the start-stop button again to stop the high voltage output.

4.5 Tree method for fault pinpointing

The tree methodology is applicable to both fault location modes and both sensor types. For simplicity the following description only refers to the clamp but is equally applicable to the sensor.

- i. The first step is to determine the branch which has the fault. Start by placing the clamp adjacent to the busbar, the feeder with the fault can be identified. Press the start button to begin the detection process. This may already be clear from the transmitter; otherwise it is determined by observing the information the receiver obtains from the clamp, which can be placed around both the positive and negative wires or just one of them. The affected feeder will be identified primarily from the value of the current measured, the voltage values and the position of the failure probability pointer, but the other data available on the receiver will also be of value.
- ii. Where the feeder splits into two branches, each branch is tested in turn, to see where the receiver registers a resistance to earth. By rejecting the lines which do not exhibit fault behaviour, the faulted line will be identified through a process of elimination. This allows the fault path to be followed to the next branch, where the process is repeated until the fault point is identified.
- iii. If the fault cannot be located the battery itself should be investigated.
- iv. If a fault has resulted in an earth loop fault on the DC system, the position where the current direction changes is the fault position (Note: the current direction on the Clamp should remain unchanged).

4.6 Typical fault pinpointing process

- i. The single point earth fault pinpointing process is shown in Figure 4.2. The Transmitter and Receiver are connected as shown in Figure 4.1 and in this case the Clamp and Receiver assembly is represented as a loop around the feeder(s).

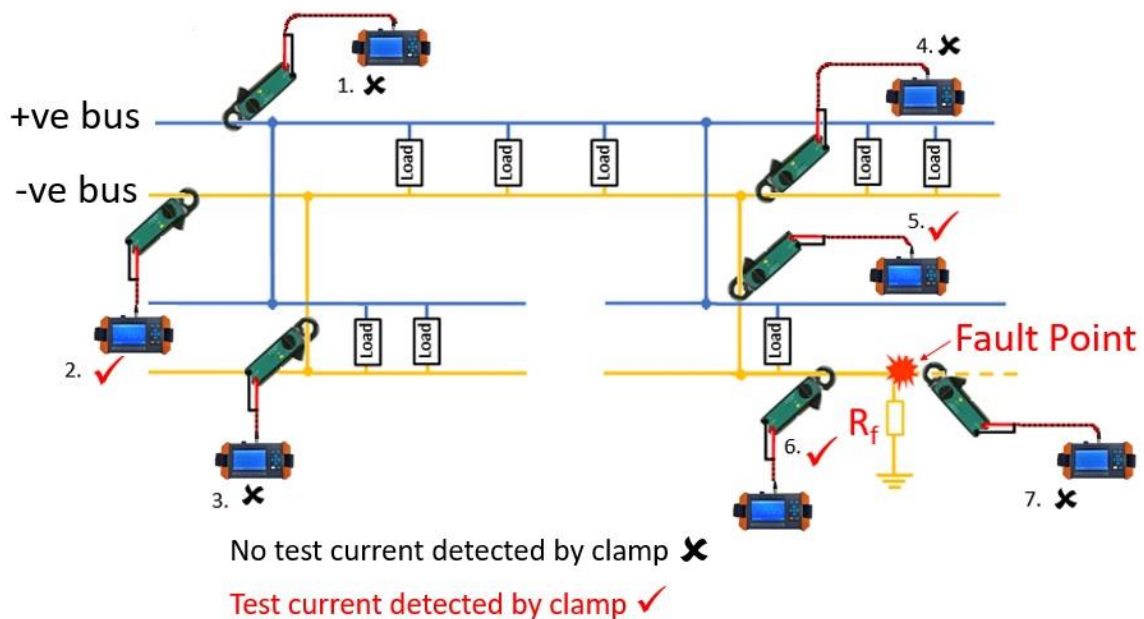

Figure 4.2 Fault pinpointing process for single earth fault

- ii. If it is identified that there is more than one fault on the system, the process for pinpointing multiple earth faults is shown in figure 4.3

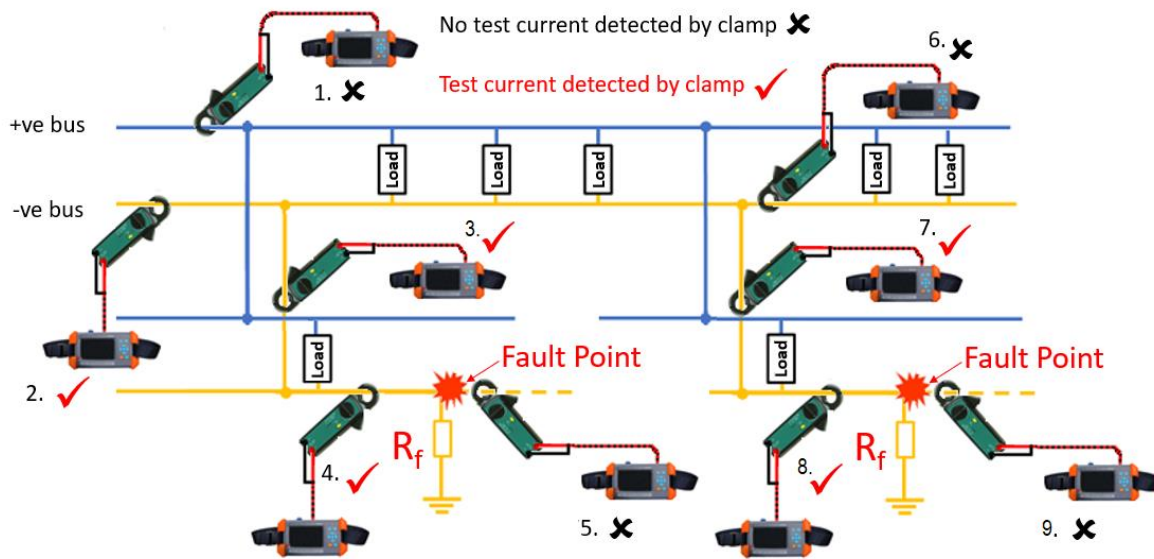

Figure 4.3 Multiple point, earth fault pinpointing process

- iii. If the topology of the system is such that it forms a loop, the earth fault pinpointing process is shown in Figure 4.4.

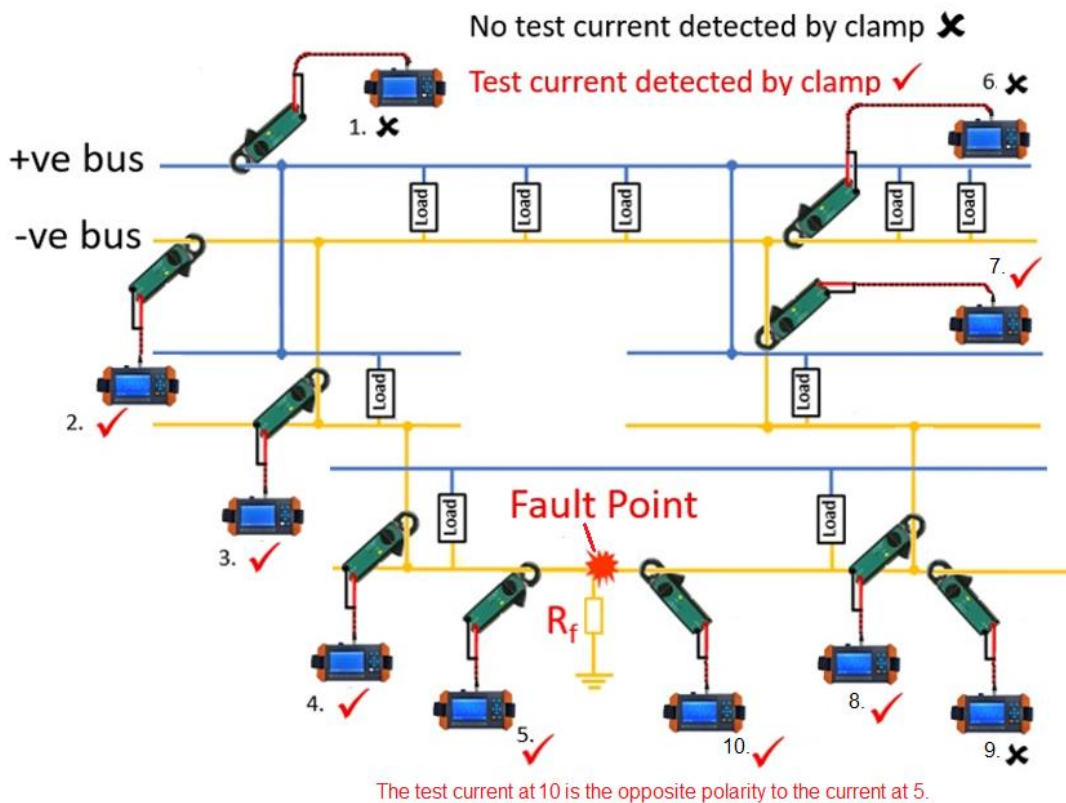

Figure 4.4 earth fault pinpointing on a loop system

5 Transportation, Storage and Charging

5.1 Transportation considerations

Use the transport bag/boxes provided to ensure that the product is well packaged if shipping.

5.2 Storage conditions, storage period and precautions

Observe the environmental conditions specified in Section 1.4 when storing the instrument. The instrument should be stored in a dry environment providing suitable protection against mechanical damage and dust. Where the instrument is not used on a regular basis, it should be stored indoors using the original packaging, and should not be exposed to the sun or rain. The room should be air-conditioned and should not contain corrosive gas. The instrument should not be subjected to severe mechanical vibration or shock and there must not be a strong electromagnetic field. If the instrument is not used for a long time, make sure that the Receiver and Clamp are turned off and the battery removed from the Clamp. Fully charge the Receiver every 10 months.

5.3 Instrument power and charging

Always use the dedicated power supply for the Transmitter (unless used in self-powered mode). Insert the power supply plug into a 110VDC, 220VDC or 220VAC, 50/60Hz power socket and insert the output plug into the Transmitter's power supply socket (figure 2.1).

Always use the dedicated charger for the Receiver. Insert the charger plug into a 220VAC 50/60Hz power socket and insert the output plug into the charging socket of the Receiver (figure 2.3). The Receiver takes 3-4 hours to charge fully.

5.4 Battery replacement

The clamp uses high-capacity alkaline dry batteries. When the battery voltage indicator on the clamp (Figure 2.5 ④) is on, the battery needs to be replaced.

First, unscrew the battery cover on the instrument, open the battery box and remove the batteries. Install the new AA (x2) batteries into the battery compartment, replace the cover and tighten the screws.

If the battery detection indicator does not turn on when the clamp is turned on, it may be that the batteries are not installed properly, they are reversed or the replacement batteries are exhausted. (Note: installing the batteries backwards may damage the instrument).

The clamp does not have an automatic shutdown function, and the power must be turned off after use to reduce battery loss.

If the clamp will not be used for a long period, remove the batteries to prevent leakage.

5.5 Unpacking and Inspection

Before unpacking for the first time, follow the steps below.

- i) Take out the document bag containing the instructions and packing list.
- ii) Check the packing list to ensure that the contents are complete and intact.
- iii) Check that the serial number is consistent with the instrument and the factory number of the warranty card.
- iv) Plug in the Transmitter, charge the Receiver and put a battery in the Clamp. Then switch them on, to make sure they are functioning properly.

6 Maintenance











As long as they are used properly, the instruments do not have any parts that require maintenance or calibration under normal conditions. If the surface of any of the instruments becomes contaminated with dirt, wipe it off with a soft, dry cloth or a soft cloth slightly dampened with a soft (non-bleach) household cleaner. As a basic principle, do not let moisture into the Receiver charging port; if the surface of any of the instruments becomes wet, dry it with a soft cloth.

7 Warranty

The instrument is guaranteed for one year from delivery for any problems arising from product quality issues. If problems occur due to improper use or are beyond the warranty period, contact Kehui International or one of its approved distributors for assistance.

Repairs attempted without the express permission of Kehui will invalidate the warranty and may lead to further damage to the equipment.

8 Appendix A: ZDT-300 Packing list

No.	Description	Photograph	Quantity.
1	DC earth fault locator Transmitter		1
2	DC earth fault locator Receiver		1
3	Clamp		1
4	Current sensor and cable		1
5	Transmitter cable (Positive, negative and earth)		1 set
6	Receiver cable		1
7	Transmitter power cable		1
8	Receiver charger		1
9	Carry case		1
10	Manual		1